



## Open Call Architectural Pride

1

### The commission

The London Festival of Architecture (LFA), and Architecture LGBT+ invite you to create a float to represent architecture and LGBT+ Architects at Pride in London and Manchester.

We are inviting architecture students, recent graduates, emerging practices as well as representatives from more established practices across London to submit a design proposal for a float to represent LGBT+ architects and their contribution to architecture past and present.

The winning design team will be commissioned to design the float and work with the contractors Sir Robert McAlpine to deliver it. The float is for the Pride in London Parade on 6 July 2019 and Pride in Manchester on 24 August. The float should cost up to £8,000+VAT. This will be a chance to participate in a unique project and showcase your imaginative design to the public.

2

### The Context

The London Festival of Architecture (LFA) is the world's largest annual architecture festival, with a mission to support London architectural and design talent, enthuse and engage with the public, and find new ways to look at familiar places. This year the LFA is exploring the theme 'boundaries'. As well as a month-long festival of hundreds of public events across London from 1-30 June, the festival also organises a year-round programme of other activities including design competitions.



The London Festival of Architecture is committed to promoting equality and diversity in the architecture and wider built environment professions.

Architecture LGBT+ is a not for profit grassroots organisation, who aim to provide a safe, inclusive & prejudice free environment for LGBT+ Architects and those working and studying within the profession through networking events, learning, mentoring and role models.

Architecture LGBT+ host a series of event throughout the year which are made possible through sponsorship. In 2019 Foster + Partners are Platinum sponsors with Gold sponsors BDP and Grimshaw Architects.

In July 2018 we built on the annual Pride Breakfast at the RIBA by launching the inaugural Architecture LGBT+ float competition for Pride London. The float received a wide range of press across the design media, including Dezeen and the Architects Journal.

In 2019 as a joint collaboration between RIBA, LFA and Architecture LGBT+ we will launch with a Pride Brunch at 66 Portland Place, the RIBA headquarters, before joining the float in the parade. In Manchester BDP are hosting the Pride Breakfast.

Homophobia is rife in the construction industry; The Architects Journal survey revealed that 39% of architects had heard homophobic or transphobic slurs in the workplace. Architecture is behind many industries with diversity, the new

Architecture LGBT+ group is providing a safe space and promoting LGBT+ role models within the industry.

We are seeking the profession's help as we continue our work to promote equality and diversity across the built environment professions.

3

## The site

London and Manchester Pride are key events for the LGBT+ community and provide a platform to raise awareness of LGBT+ issues and campaign for the freedoms that will allow them to live their lives on a genuinely equal footing.

The Pride in London Parade takes place on Saturday 6th July 2019 from 12.00pm. The parade starts on Portland Place outside the RIBA and takes over the West End of London, thousands march in the parade and around 1million people watch it.

Pride in Manchester's parade is held Saturday 24<sup>th</sup> August through the city centre and this year is focused on imagining a future world of equality.

4

## Design requirements

The float design is open ended but must be in the spirit of Pride. The LFA theme of Boundaries can carry through to the float.

The float will be viewed from both the sides, the front and the back, with the Architects walking behind the float.

The float must fit onto a flatbed truck, the truck will be:

MAN/TGL 10-180 7.5 dropside truck. The total size of the truck is:

The flatbed to which the design must fit is: 6680 (L) and 2490 (W), the deck level of the truck is 1130mm from the ground and the top of the side panels are 1530 from the ground (400mm on all three sides). See attached illustration of truck at the end of this document; please note the truck illustration is for guidance purposes only.

The total dimensions of the Float to fit within Pride in London requirements are: maximum 4.5m high to fit under the arches at the start of the parade, 10m long and 2.5m wide.

The float design must incorporate speakers: there will be four speakers on the float which can be arranged in two ways which are demonstrated in the illustration at the end of this brief: Option 1 is to put all four speakers together, and the dimensions of this arrangement is 1780h x 2040w x780mm deep. Option 2 is to stack the speakers two by two as seen in the illustration.

A generator, 1500mm (w) 880mm (l) 1100mm (d) by will be provided to for power, it will need to go against the headboard and contain an exhaust.

The float should be easy to demount, transport and reconstruct for both festivals.

Architecture LGBT+, the LFA and the RIBA have a combined allocation of 190 wristbands for the parade to walk with the float, these can either all walk behind the float or the float can incorporate people on board with suitable health and safety precautions. If the float design includes people on board then it needs to be safe for access and leaving the float with two handrails, including one at low level, to prevent falling. Everyone must enter the float before the parade starts and cannot leave it until the end of the parade.

Placards need to be designed for the walking group, designed as part of the competition. The placards will need to be prominent for Architecture LGBT+ with some placards also to include other logos. T-shirt design for Architects walking in the parade should also be included.

The float will require logos, the most prominent of which needs to be Architecture LGBT+. Additional logos will need to be added in the design development stage including: LFA, RIBA, Foster & Partners and Winning team logo. Do not include your practice logo on the submission as it is a blind competition.

### Further guidance

- Budget: The float should cost up to £8,000+VAT. Placards, T-shirts, speakers and a generator will be provided by Architecture LGBT+, so this does not need to be factored into the budget.
- Health & safety: The float needs to be stable and structurally sound. No petrol generators are allowed. If the input of a structural specialist is required it will be the responsibility of the winning team to provide this.
- Construction: Sir Robert McAlpine will deliver the float design. The winning team will need to allow time to liaise with the contractors for the design and to turn around drawings as required within the tight timescales. They will also need to attend site as required.
- Durability: The design needs to be suitable for heavy rain or sunshine, it will need to survive the duration of the events, plus travel to and from each city.
- Availability: The winning team will need to be available in both cities prior to and after the parade to ensure that the float is set up and ready for the parades.
- Approvals: The winning team will be expected to provide measured plan and elevational drawings of the float for Pride in London approval maximum 1 week from announcement of win. Construction drawings will need to be provided for SRM to deliver the float.

5

## Submission

Submission must be made via the LFA website.

[www.londonfestivalofarchitecture.org/pride2019](http://www.londonfestivalofarchitecture.org/pride2019)

During the submission process you will need to submit:

1. Full name and contact details including postal address, contact number and email of project lead. These details should not be included on the PDF.
2. A single A1 page in PDF format including:
  1. Hand or computer drawn 3D design visualisation
  2. Construction detail drawn to scale with key dimensions noted, outline all materials, budget and costings, production process and disposal

Do not include identifying information on your PDF as the competition is to be judged anonymously.

6

## Eligibility

The competition is open to all but we ask you to carefully consider why you are entering and the community being represented.

7

## Deadline and submission details

- Deadline for first submission is midday on 10 June 2019. Submissions received after this time will not be considered.
- For competition enquires please contact: [info@londonfestivalofarchitecture.org](mailto:info@londonfestivalofarchitecture.org)
- Submissions must be submitted via the London Festival of Architecture website [www.londonfestivalofarchitecture.org/pride2019](http://www.londonfestivalofarchitecture.org/pride2019)
- The PDF should be no more than 5MB
- You will receive an email confirming receipt of your submission.

8

## Schedule outline

Submissions open: 14 May 2019

Submissions closed: midday 10 June 2019

Winners will be announced at an evening event on 13 June 2019

London Pride: 6 July 2019  
Manchester Pride: 24 August 2019

9

### Judging panel

Anne Cosentino (equality, diversity and inclusion manager, RIBA)  
Evan Davis (BBC broadcaster and presenter)  
Tom Guy (founder and Chair Architecture LGBT+)  
Sarah Habershon (architect, Hawkins\Brown)  
Tamsie Thomson (director, London Festival of Architecture)  
Rob Wilson (architecture editor, Architects' Journal)  
Sir Robert McAlpine representative – name to be confirmed

10

### Further information

- Submissions will be judged on originality, demonstration of creativity and relevance to the brief, as well as feasibility and how the proposal works in the context of the site. Particular weight will be given to designs that demonstrate easy demountability.
- The ownership of Copyright of the design will be in accordance with the Copyright, Designs and Patents Act 1988, that is Copyright rests with the author of the submitted design.
- All designs remain the intellectual property of the designer however the winning design when built, will be the property of Architecture LGBT+
- Please bear in mind that the project requires a fast turn around and may have peak moments when your practice will need to dedicate sufficient staff to deliver the project on time, on budget and to the high standard expected by all stakeholders.
- Your practice/collaboration needs to have the following insurance, to a sum relevant to the project budget, in order to be eligible to be selected: Employers Liability, Professional Indemnity.
- Significant efforts are made by all stakeholders of the project to ensure wide media coverage.
- London Festival of Architecture and Architecture LGBT+ reserve the right to use images from the submissions for promotional purposes in press, social media and publications. All endeavours will be made to ensure accurate accreditation.

11

### Useful links

London Festival of Architecture:  
[www.londonfestivalofarchitecture.org](http://www.londonfestivalofarchitecture.org)

Pride in London  
[www.prideinlondon.org](http://www.prideinlondon.org)

Manchester Pride  
<https://www.manchesterpride.com>

Architecture LGBT+  
[www.architecturelgbt.com](http://www.architecturelgbt.com)

12

## Contact

For general enquires please contact: [info@londonfestivalofarchitecture.org](mailto:info@londonfestivalofarchitecture.org)

13

## Disclaimer

The competition organisers are not liable for lost, misdirected, or late entries. Decisions of the jury represent their professional judgments and all decisions are final. While it is the intent to construct the winning scheme, the organisers reserve the right to not proceed with construction for any reason. Material submitted by you shall be your sole responsibility, shall not infringe or violate the rights of any other party or violate any laws, contribute to or encourage infringing or otherwise unlawful conduct, or otherwise be obscene, objectionable, or in poor taste. By submitting such material, you are representing that you are the owner of such material and/or have all necessary rights, licenses, and authorization to distribute it.

14



## London Festival of Architecture

The London Festival of Architecture was founded in 2004, and is now firmly established as the world's biggest annual architecture festival. The London Festival of Architecture 2019 will feature events across the capital from 1-30 June, and this year will explore the theme 'boundaries'. The London Festival of Architecture celebrates London as a global hub of architectural experimentation, practice and debate, provoking questions about the contemporary and future life of the city, and promoting positive change to its public realm. The London-wide programme is delivered by a diverse mix of architecture and design practices and practitioners, cultural and academic institutions, artists and many others.

[www.londonfestivalofarchitecture.org](http://www.londonfestivalofarchitecture.org)  
Twitter: @LFArchitecture



## Architecture LGBT+

Architecture LGBT+ is a not for profit grassroots organisation run by volunteers who all work within the industry. We aim to:

Provide a safe, inclusive & prejudice free environment for LGBT+ Architects and those working and studying within the profession through networking events, learning, mentoring and role models.

We started in 2016 with a pre pride Breakfast we hosted at the RIBA with a Q&A chaired by BBC's Evan Davis. In 2018 we also launched with a pride Breakfast in Manchester. In 2019 we are planning additional Pride Breakfasts in Newcastle and Brighton.

Platinum sponsor: Foster + Partners

Gold Sponsors: Grimshaw Architects and BDP

Silver Sponsors: Jamie Fobert Architects, Stanton Williams, Make

Bronze Sponsors: Feix & Merlin, Ashton Architecture and Project Orange

[www.architecturelgbt.com](http://www.architecturelgbt.com)

Twitter: @ArchitectLGBT

Instagram: architecturelgbt



Plan - MAN/TGL 10-180 7.5 tonne dropside truck

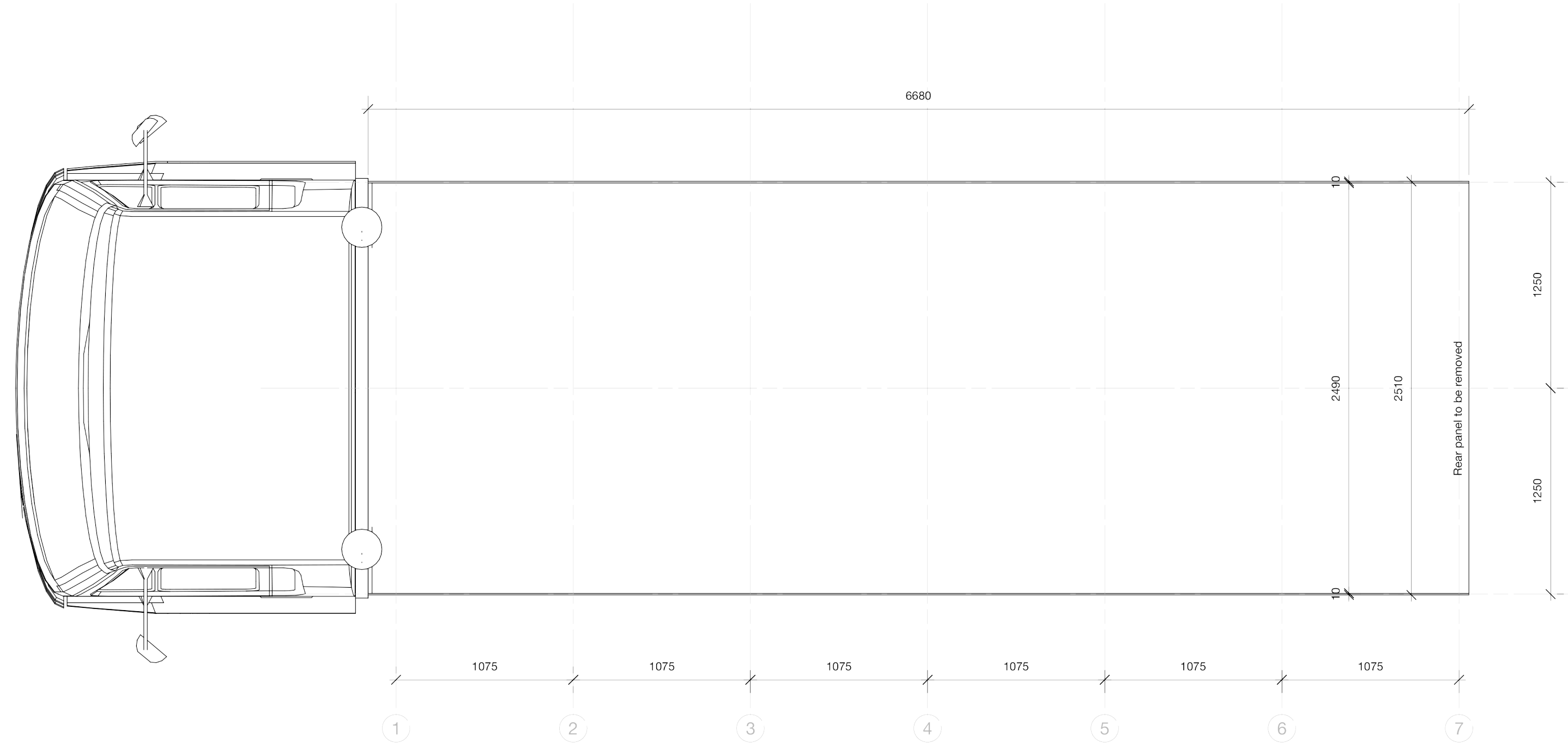

1. MAN/TGL 10-180 7.5 tonne dropside truck

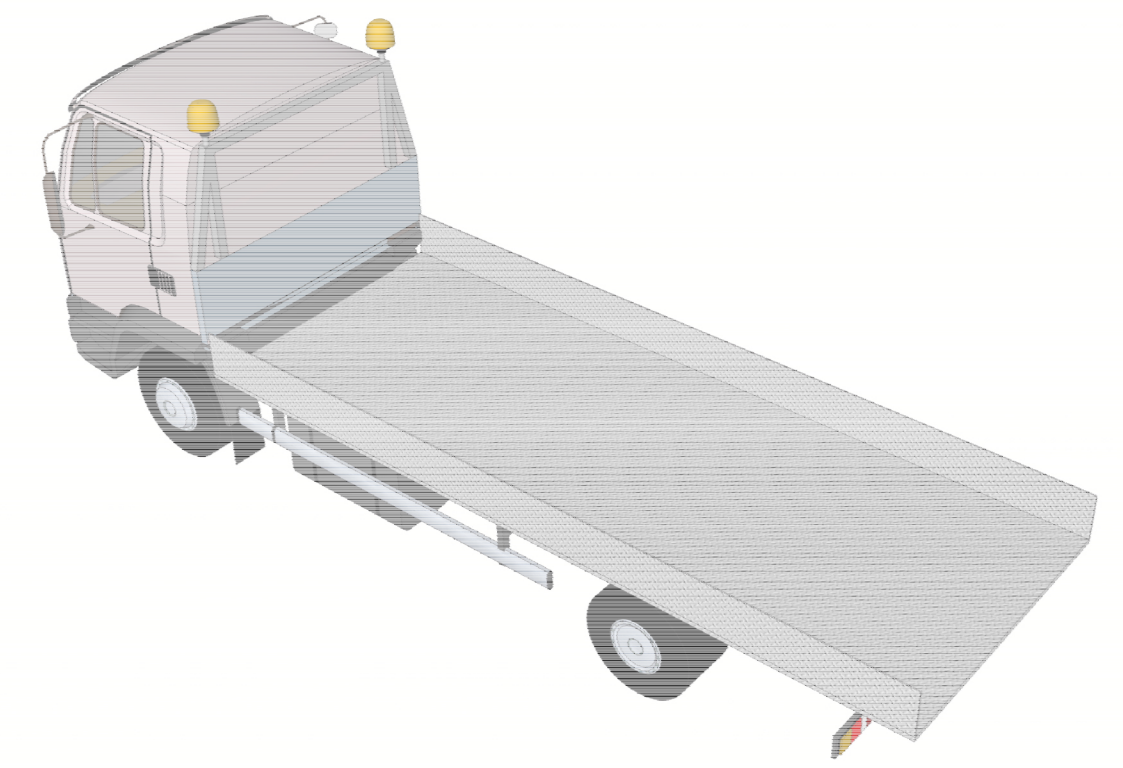

Side Elevation - MAN/TGL 10-180 7.5 tonne dropside truck

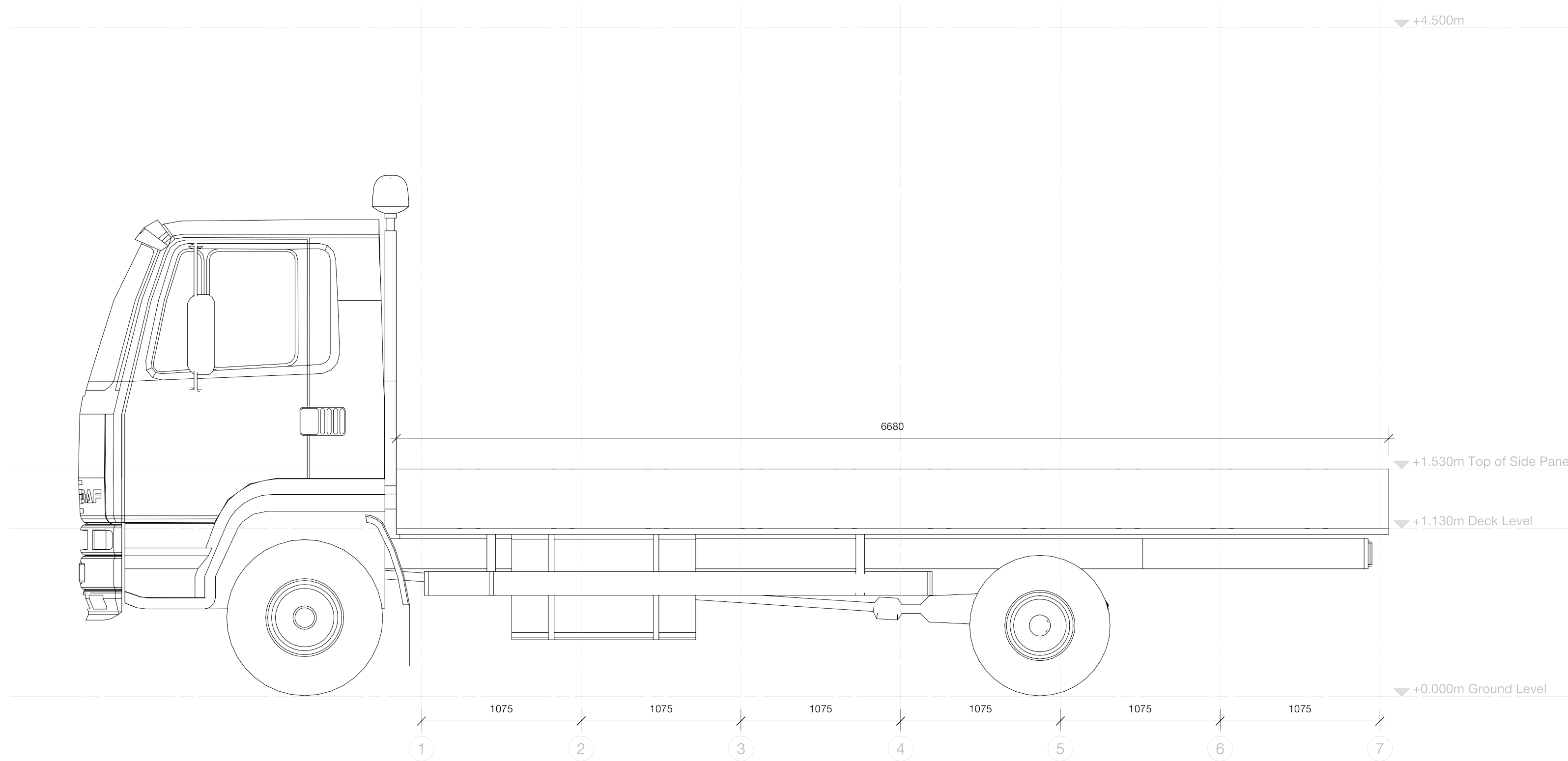

Rear Elevation - MAN/TGL 10-180 7.5 tonne dropside truck

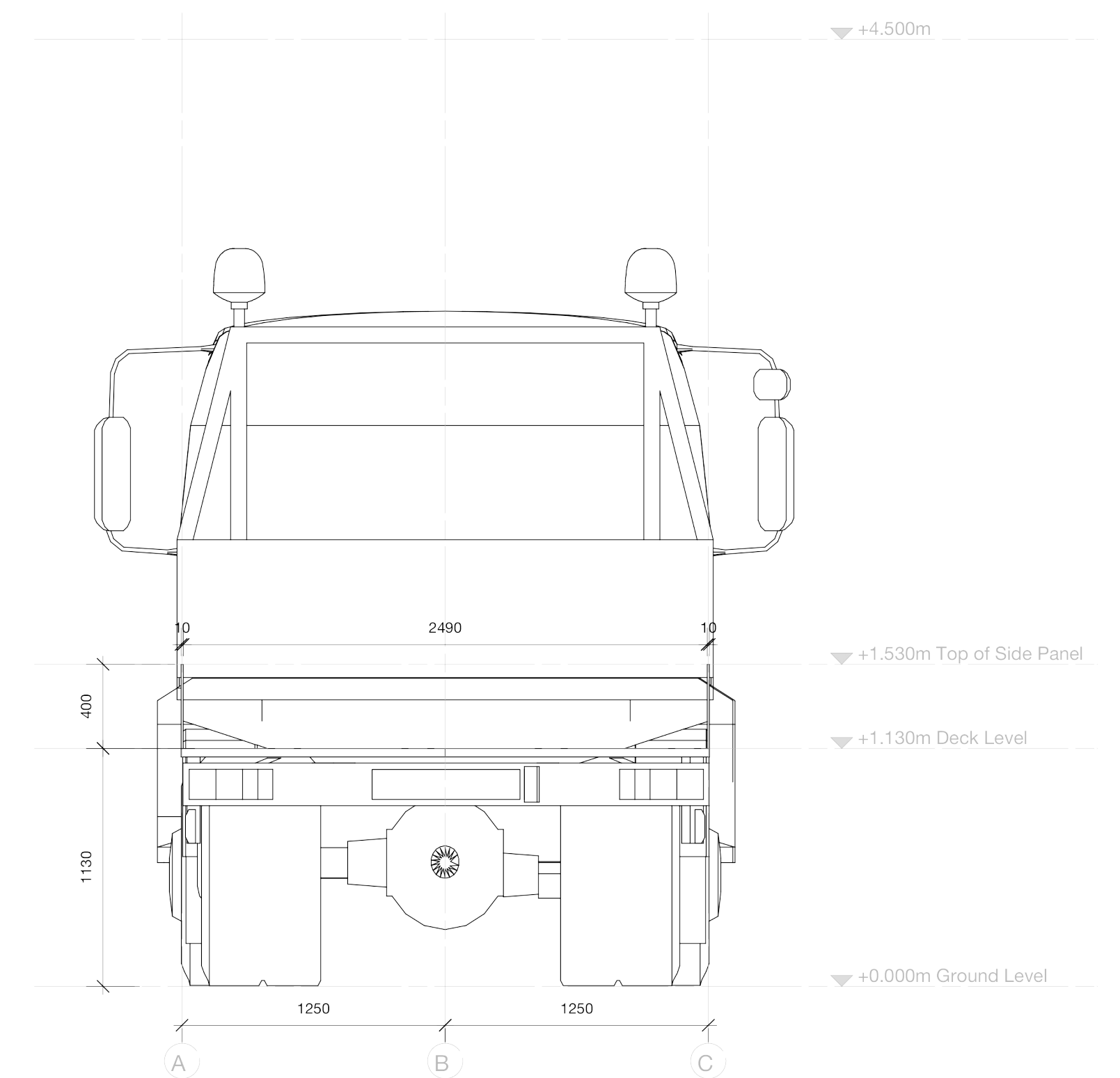

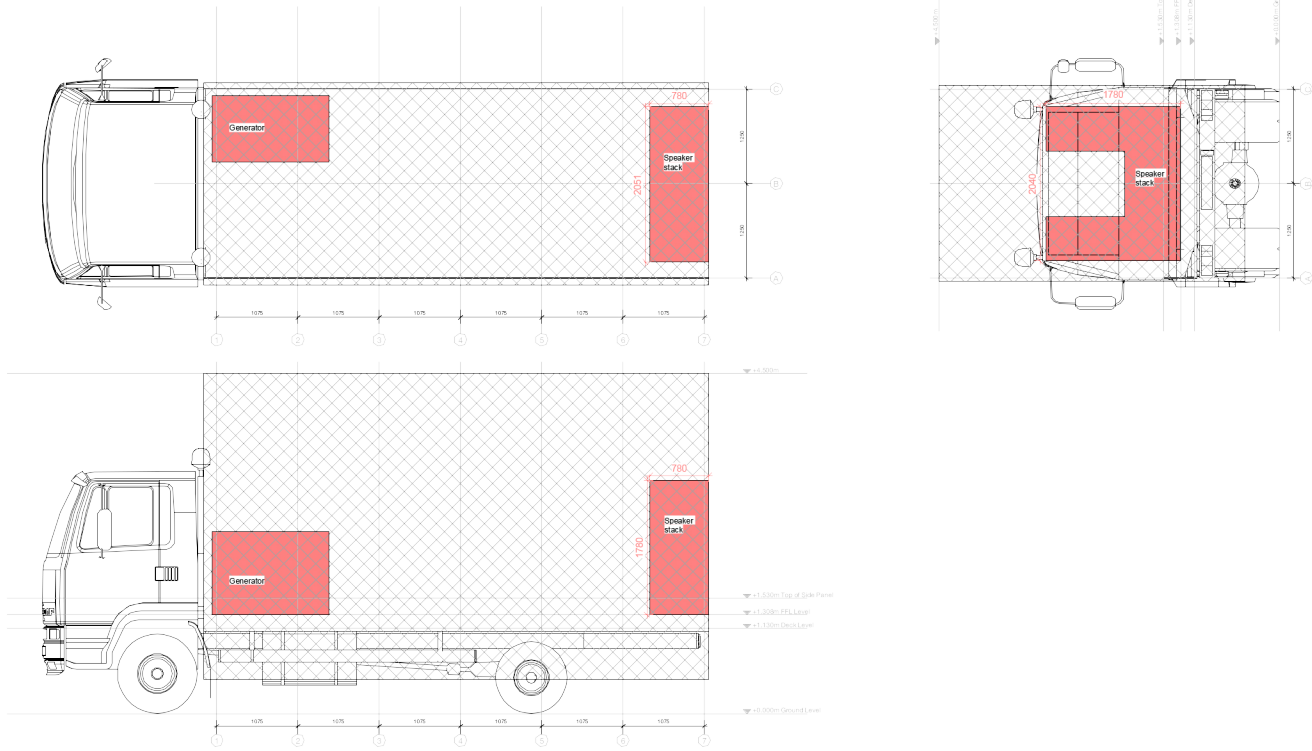

**A** Opt 1. Speakers  
1 : 50

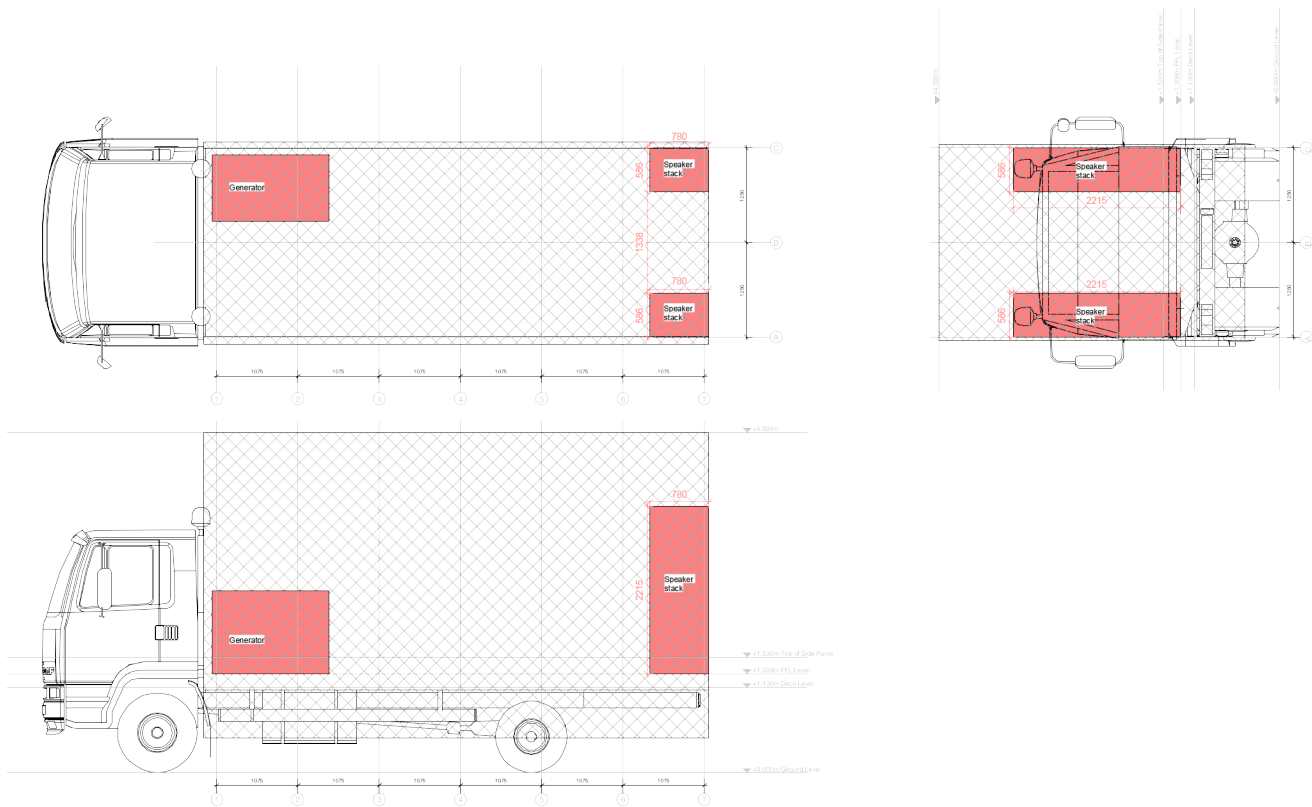

**B** Opt 2. Stacked Speakers  
1 : 50